

Amama project

3329



NATUZZI
ITALIA

Amama 3329

Amama, a term that in some African languages evokes the maternal figure. In the world of furniture design recalls spaces that tell stories of generations, conveying warmth, comfort, and serenity. Its palindromic name, symmetrical in both form and sound, reflects the very essence of the project: a double-sided sofa with a harmonious, unique, and easily memorable design.



Design by Andrea Steidl

Andrea Steidl graduated in Industrial Design from the Polytechnic University of Milan in 2004, with a thesis on "Gratuity." After moving to Milan, he joined Patricia Urquiola's studio, where he took on the role of design manager. In 2016, he created his first personal project and later co-founded the studio \ar-o\ with Raquel Pacchini, focusing on product design, communication, strategic consulting, and art direction projects.



Choose your Amama 3329

The Amama project is extremely versatile, thanks to its 25 SKUs, which allow for unlimited configurations suitable for any space, from retail stores to the homes of our customers.

chair with arm

272 274

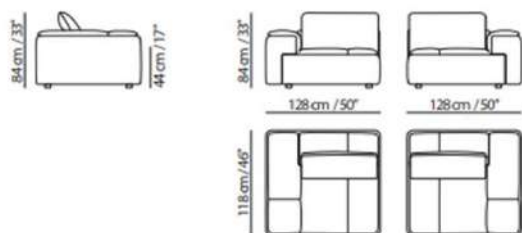

armless chair

291

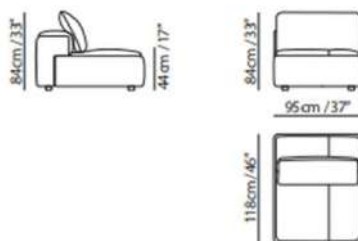

armchair with arm that can also
be used as a corner

032 033

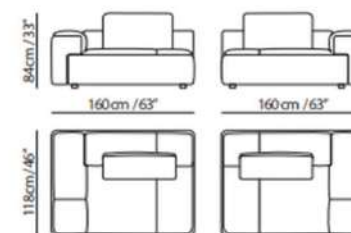

seat with terminal

072 073

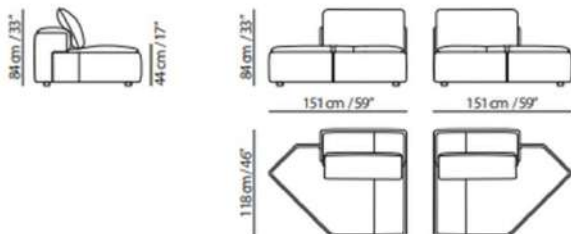

chaise longue

047 049

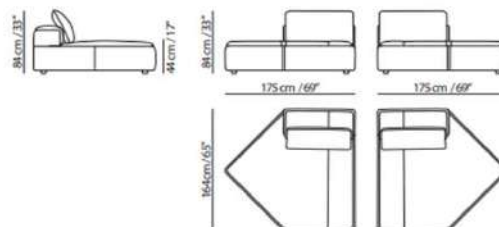

ottoman

010



optional back cushion

126

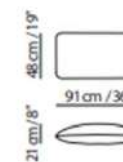

Versatility and Configurations

The Amama project is extremely versatile, thanks to its 25 SKUs, which allow for unlimited configurations suitable for any space, from retail stores to the homes of our customers.

chair with arm and recessed back

876 878

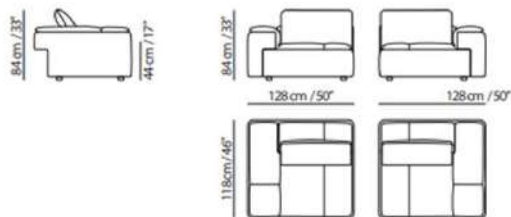

armless chair and recessed back

891

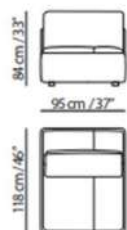

armchair with arm that can also be used as a corner and recessed back

832 833

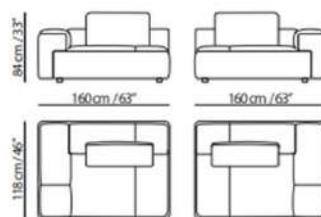

seat with terminal and recessed back

872 874

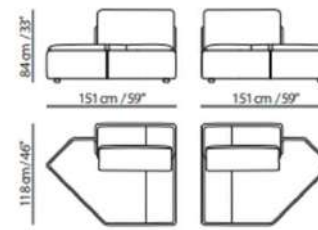

chaise longue with recessed back

877 879

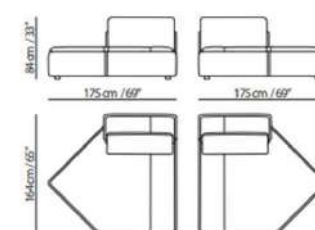

small seat without backrest

298

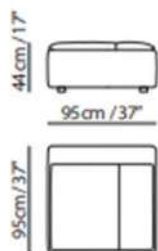

large seat without backrest

299

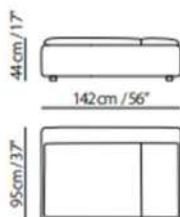

open cabinet

820

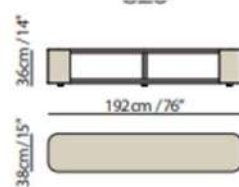

bookshelf

827

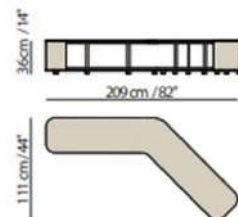

bookshelf left and right

816

817

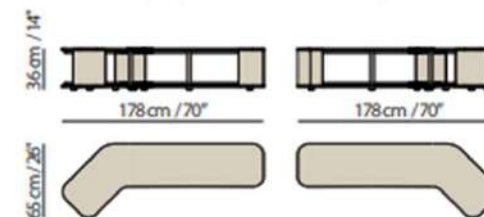

Versatility and Configurations

The “Versions and Compositions” chart aims to showcase the full versatility of the project. In particular, Amama offers elegant design solutions with integrated table top.



272+274

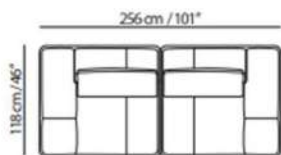

272+291+274

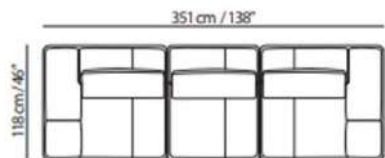

272+291+872+816

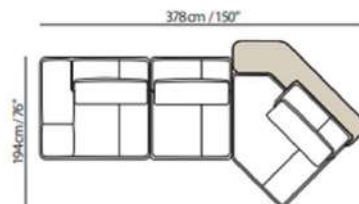

010+872+274+816

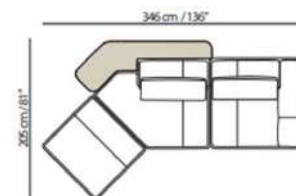

272+010+872+274+816

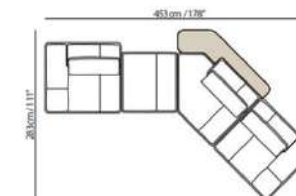

272+291+032+291+073

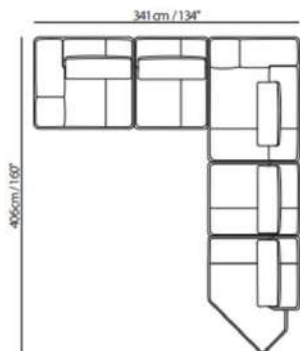

010+872+874+891+891+274+298+089+817+820

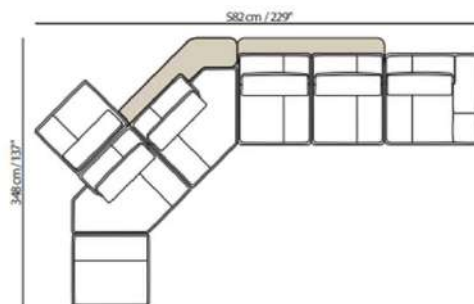

272+872+874+274+816+817

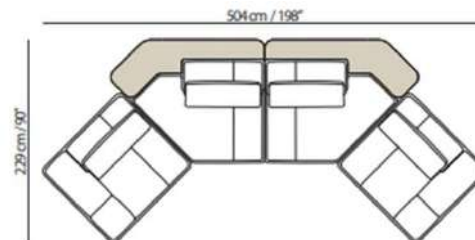

Thanks to the configurator, this versatility can be customized according to the client's needs.

Technical features

Amama recalls spaces that tell stories of generations, conveying warmth, comfort, and serenity.



Design and Versatility

The modular island sofa is a sophisticated and versatile option, ideal for modern and dynamic environments. Made up of fully upholstered modules, this system allows for countless configurations, perfectly adapting to any space. Each module is designed to provide optimal comfort and support, with an elegant and contemporary line that fits various décor styles.

The distinguishing feature of this sofa is its ability to offer bifacial solutions, perfect for placement in the center of the room. This island design allows you to enjoy the same aesthetics and comfort from both sides, creating an elegant focal point that invites conviviality.

Ideal for those seeking a flexible, modern, and visually impactful solution, the modular island sofa is a distinctive and sophisticated element for any environment.

Features

Coverings: The sofa is available in leather (starting from category 30 Stromboli) and fabric. Not available in Misterbianco.

High-quality padding: All padding is certified, ensuring maximum comfort, support, and durability over time.

Seat cushion: The seat cushion perfectly combines support and comfort with its innovative structure: a solid and durable base made of high-density polyurethane (40), a 2 cm layer of memory foam that molds to the body, relieving pressure points, and a feather-filled topper that provides enveloping softness and superior comfort, promoting ultimate relaxation.

Back cushions: Also padded with down for a soft and supportive feel.

Hidden metal feet: Anti-slip metal feet for greater stability and a clean design.

Modularity without connections: Each module is fully upholstered on all sides, with no need for connectors between the seats

Integrated system of back consoles made of glossy lacquered wood fiber, available in two finishes: teal and praline.

Layout Examples

It is also possible to express the versatility of the project through different layouts, suggesting the creation of various room sets to show the optimization of spaces in any living area.

DIM: 16 SQM / 170 SQFT

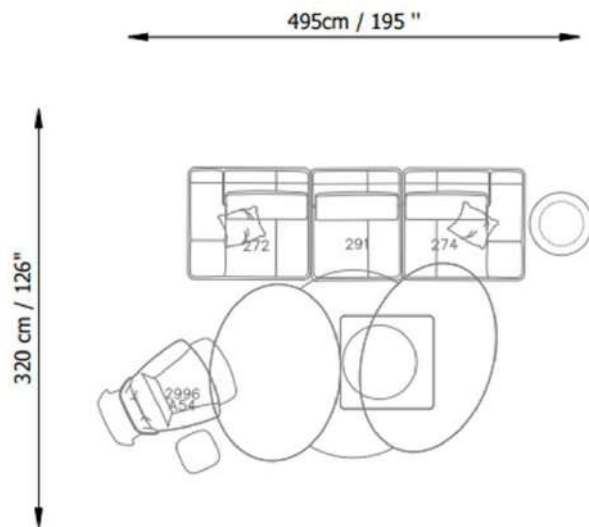

DIM: 25 SQM / 269 SQFT

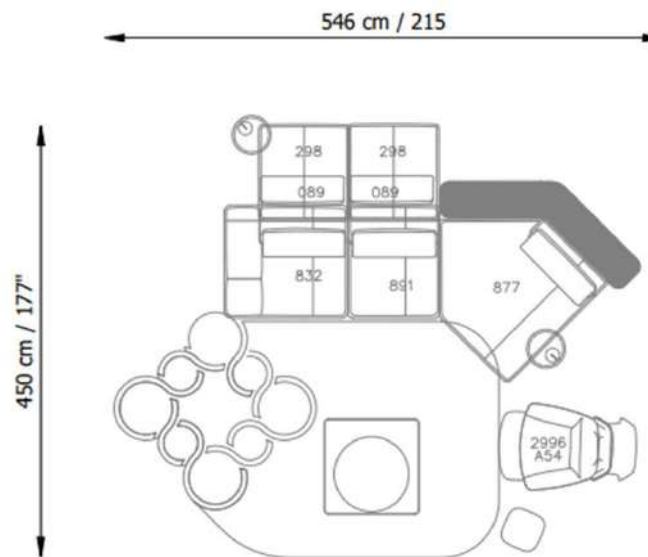

DIM: 31 SQM / 334 SQFT

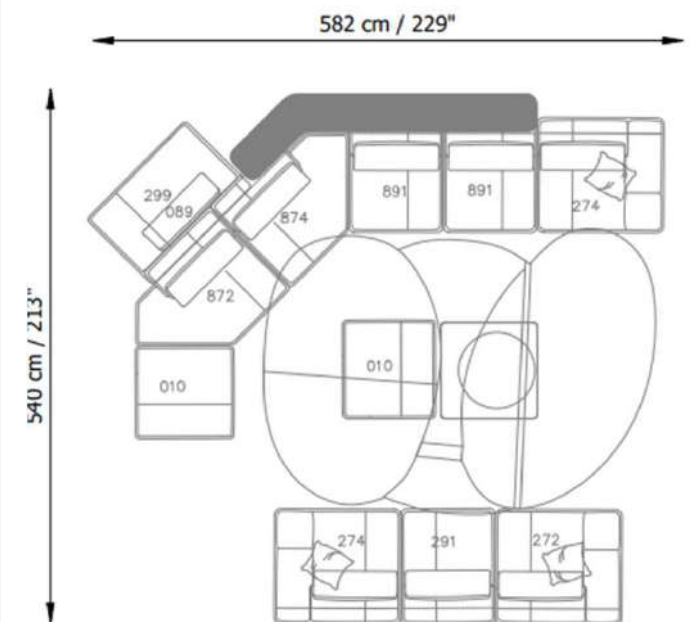

Moodboard Green

To achieve harmony in every project, the Natuzzi Style Center carefully selects materials and coverings. In this case, glossy lacquer Teal and Smoked Oak has been paired with Salina Leather and Settecoggi and Marechiaro fabrics that defines the overall final look of the project. Each model in the collection is presented with multiple moodboards to suit all market geographies.

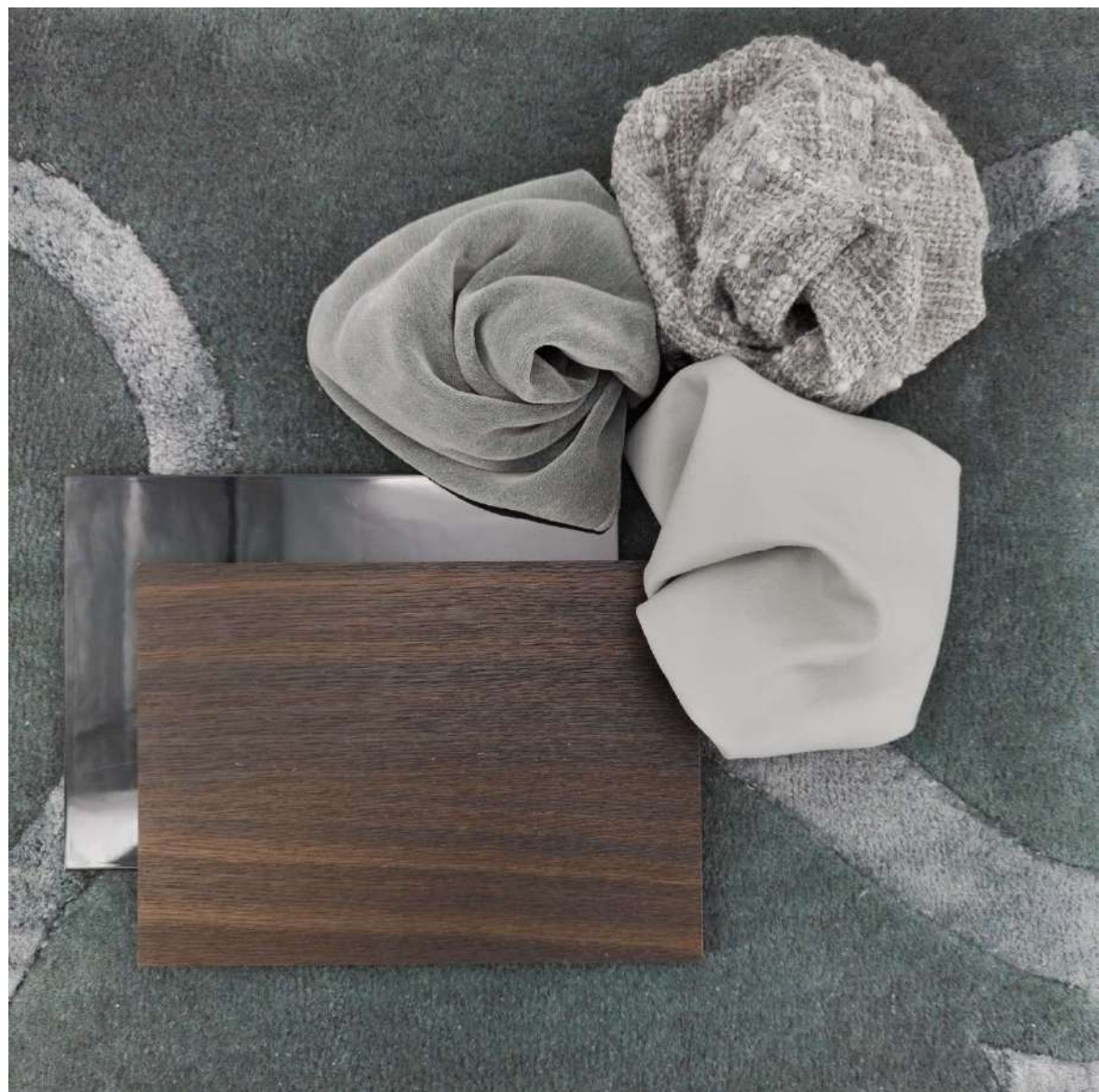

Moodboard green

Along with the moodboard of coverings and materials, the Natuzzi Style Center harmonizes the living room with furniture and accessories to complete the interior design project.



SETTECOLLI 88.0090.05



SALINA 351A



OTTOMAN
MARECHIARO 99.0036.04



Central Coffee Table HABITA
Smoked oak L97 P97 H38
Q987001XNA

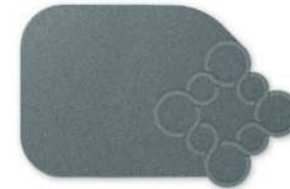

Rug RADICE
260 X 400 JADE
V189001XNA

These products have been carefully selected to maintain the atmosphere and harmony of the design. Therefore, while the sofa configurations can be changed to fit the space and personal needs, the combination of colors, materials, and finishes cannot be altered.